



OPTIMUS 400/800

Drive for swing gates
Manual 16.06.001.002



Be sure to read this assembly manual thoroughly.

The relevant safety standards must first be taken into account.

Gates that have been placed before 01-11-2000 or 01-06-2001 must meet the requirements for health and safety that have appeared in BGR 232.

Gates which were subsequently brought into service must comply with the following European Standards:

- Since 01-11-2000 **DIN EN 12604 / 12605**
- Since 01-06-2001 **DIN EN 12453 / 12445**

The date of commissioning of the installation applicable here!

1. Description

The drive mechanism of the type OPTIMUS consists of a water-resistant steel housing and watertight aluminium cover plates. It features a self-locking worm gear, an adjustable slip clutch (depending on the desired torque), build-in limit switches and an AC motor 230V/400V.

The standard equipment includes a rotating arm with a door link bracket.

An additional lock is, due to the self-braking mechanism of the drive, not necessary. The straight pivot arm can manually be unlocked in case of an power failure. The swing gate can now be manually opened.

2. Assembly

This drive unit can be mounted underground, above ground or with slight modification, mounted on a ceiling.

The installation must be carried out according to the following dimensions; any other placement may affect the performance of the drive mechanism. The drive can be mounted perpendicular, in an angle or along the gate as long as the distances of the two pivot points are respected.

Double swing gates should have one drive per gate. Both drives can be operated separately or together (of course with appropriate controllers).

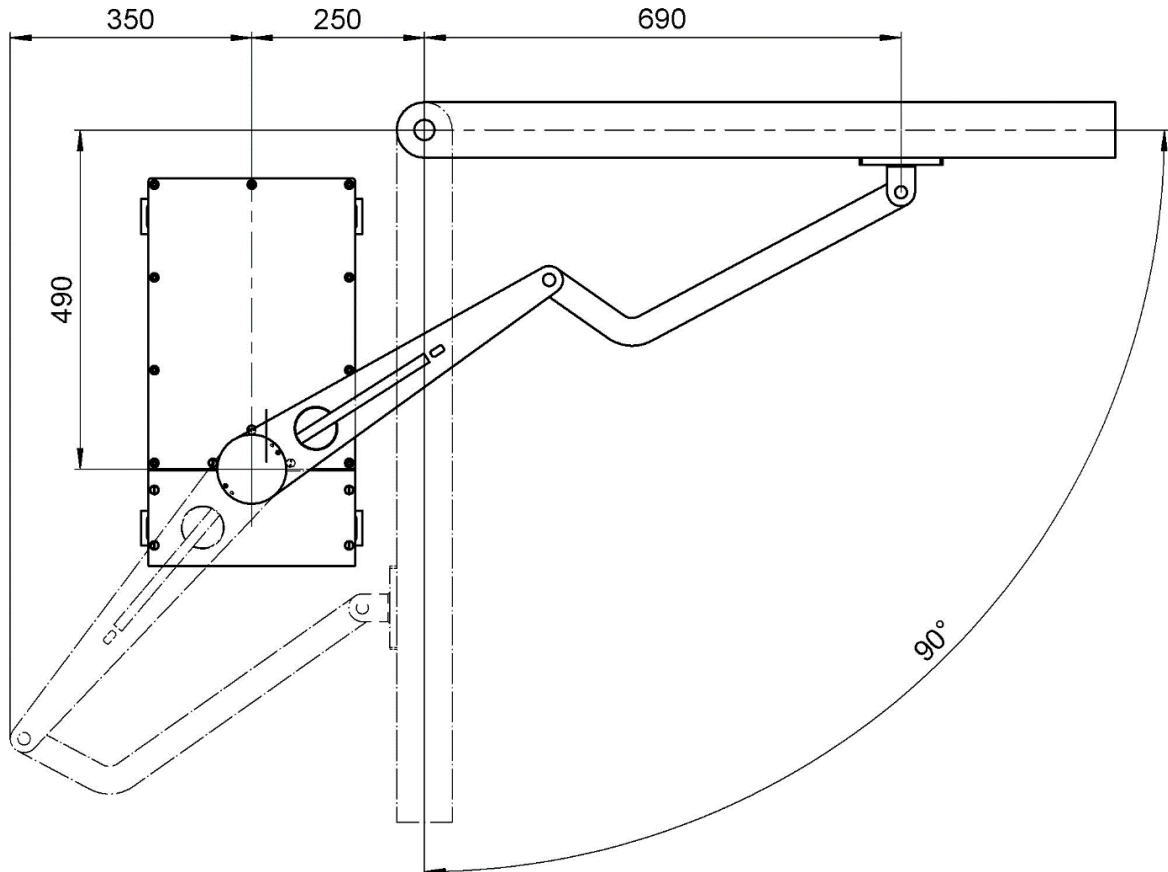

2. Assembly

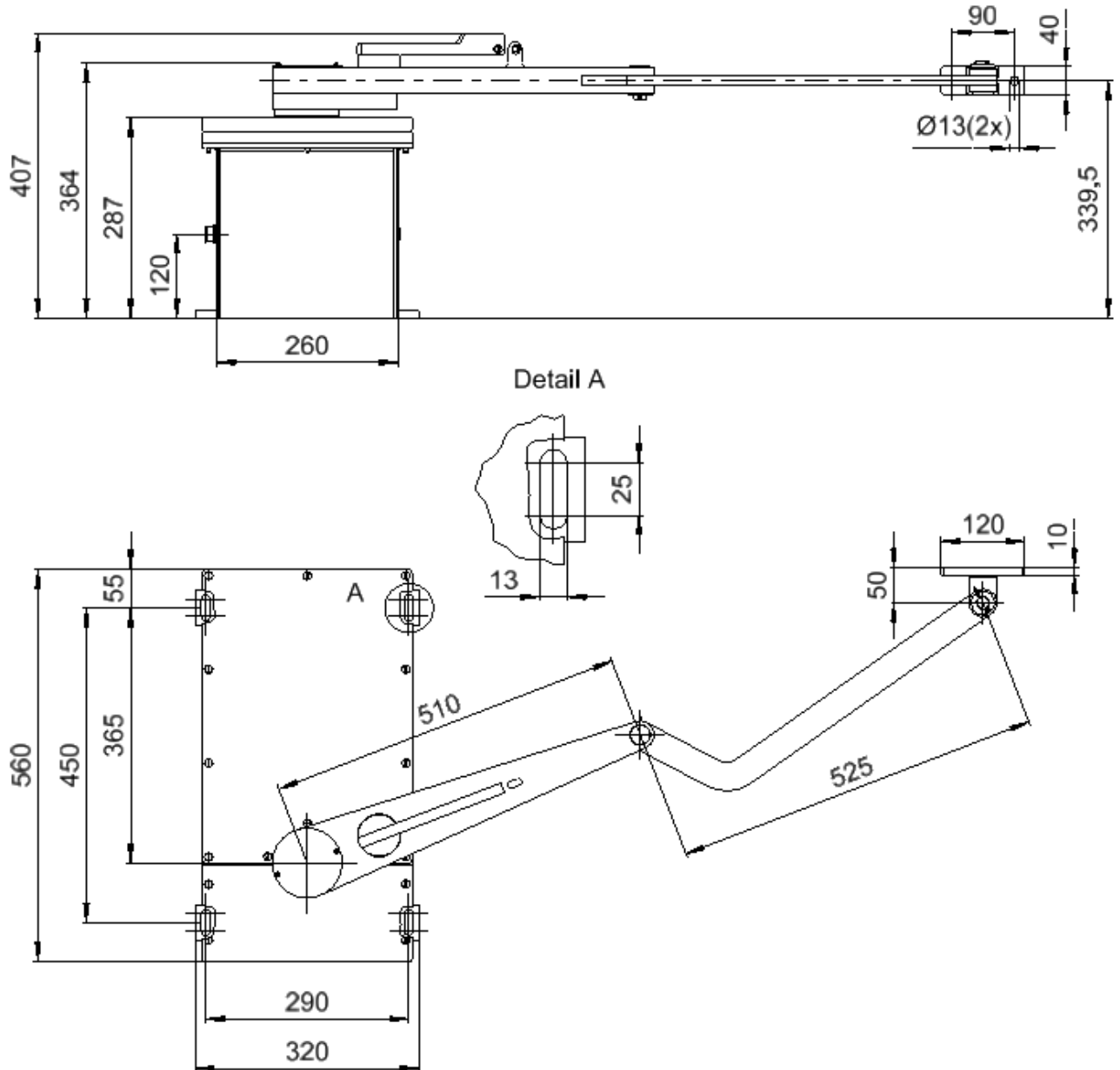



*Electronische besturingen
Contrôles électroniques
Electronic controls
Elektronische Steuerungen*



*Aandrijftechniek voor poorten
Motoréducteurs pour portes
Gear motors for doors and gates
Torantriebstechnik*

3. Setting the limit switches

The limit positions should be set after assembly by shifting and tightening the switching cams (2).

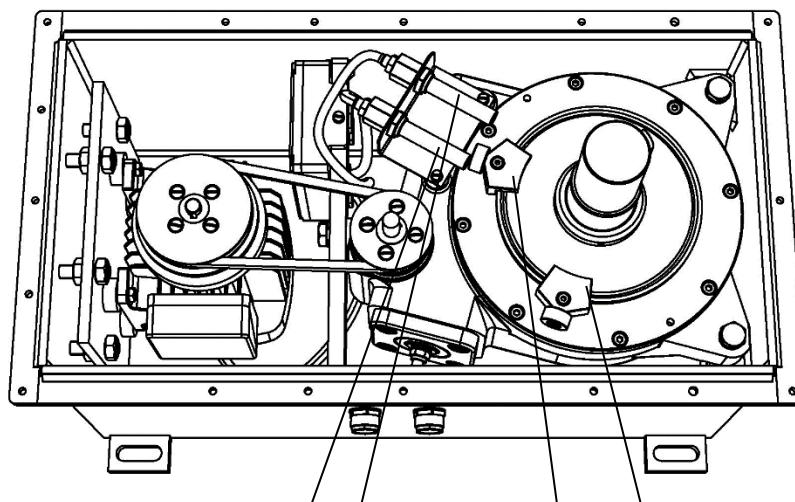

Limit switches (1) Switching cams (2)

4. Setting the friction clutch

The friction clutch is set as follows:

- Untighten the lock nut (3) and tighten the adjusting screw (4) until the swing gate can be held still manually.
- Turning the adjusting screw (4) to the right increases the friction torque; to the left decreases the friction torque.
- After setting the friction clutch, tighten the lock nut (3) again.

In the meantime, the bolt should be held with a wrench (no. 13) so the set friction torque does not change.

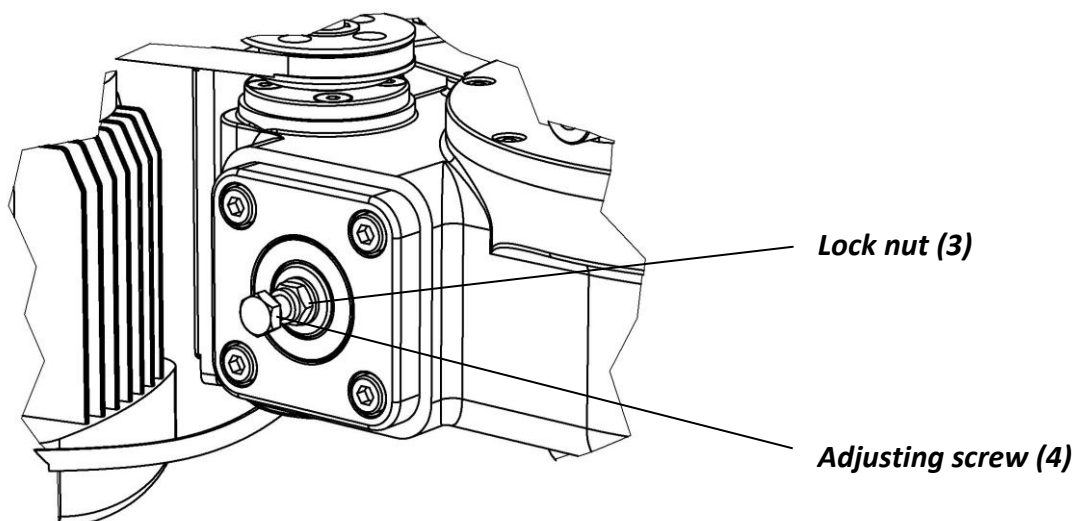

5. Opening the swing gate in case of power failure

Loosen the lever for manual control (B) counter clockwise from the pivot arm (A) and remove it. After that the gate can be opened by hand.

To electrically operate the gate again, repeat the previous steps in the reverse order.

First, move the gate to the position in which it was unlocked, then turn the lever for manual control (B) clockwise until the lever is back in line with the pivot arm (A) (the manual clutch can be secured by means of a padlock).

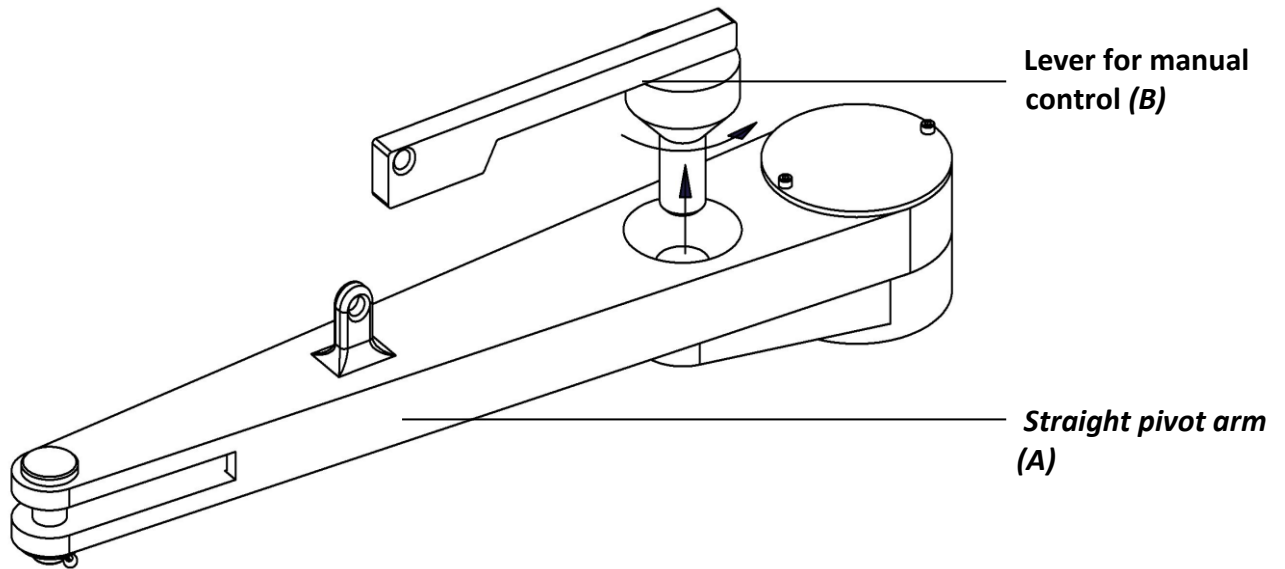

6. Electrical connection

CAUTION: always remove the fuses when working on the installation!

