



Wiegand Reader Module

Impro (WRM) Wiegand Reader Module

INSTALLATION MANUAL

SPECIFICATIONS

The WRM is a Cluster Expansion Module that works in conjunction with an Impro (CCM) Cluster Controller Module; offering a Wiegand Reader Interface solution that is adaptable and scalable, while also accommodating legacy hardware and software suites.

Working Environment

Plastic Housing (HMW700)	Designed to work in an indoor (dry) environment similar to IP20. The Module is not sealed against water.
PCB Card for IPS / 19" Rack (HMW701)	Designed to work in an indoor (dry) environment similar to IP20. The Card is not sealed against water.

Power

Input Voltage	12 V DC to 15 V DC, polarity protected.	
Power Requirements	Current (mA)	Power (W)
12 V DC with no Readers connected and relays off.....	37	0.44
12 V DC with both relays activated and maximum reader load.....	503	6

Communication with the Cluster Controller Module

Direct Communications	When the WRM is clustered (plugged side-by-side) directly into the CCM, or into an existing Cluster, or installed as a PCB Card in IPS Housing.
Electrical Interface.....	Proprietary Cluster-Bus
Baud Rate	115 200
Encryption	AES Encryption

S-Bus Device Port

Electrical Interface.....	Proprietary S-Bus
Baud Rate	9600
Encryption	AES Encryption

NOTE: *The Wiegand Reader Module (being a Twin Reader Interface) can make use of TWO S-Bus Addresses; this must be borne in mind when connecting these modules to their Cluster Controller Module via S-Bus. No more than eight Addresses should share an S-Bus. See **WRM Address Information** on page 17 for Address usage with one Reader connected.*

Reader Options

Reader 1 Wiegand and Reader 2 Wiegand allow connection to the following hardware: Impro (MDR) Multi-discipline Reader, Impro (XFM) Multi-mode Remotes, Wiegand Readers, Impro (IR) Infrared Receiver or the Impro (QR) Quad Receiver. The function is selectable via the DIP-switches (See Table 1).

Power Output	12 V DC and 5 V DC (selectable) at maximum 200 mA.
Modes Supported	Tag + PIN-code or Reason Code.
Baud Rate	9 600.
Data Format	8 data bits, no parity, 1 stop bit.
Electrical Interface	TTL Full Duplex.
Communications Protocol	Impro Proprietary Protocol.

Relays

Relay Output	2 Relays, Form C, each with NO, COM and NC contacts.
Relay Contact Ratings	10 A at 28 V DC, 5 A at 220 V AC, 10 A at 120 V AC.
Operations	100 000 Minimum.

Digital Inputs

General

Type	2 Dry-contact inputs with End-of-line (EOL) Sensing and 2 Dry-contact inputs without End-of-line (EOL) Sensing.
Detection Resistance Range	< 2 kOhm.
Protection Range	+15 V continuous.

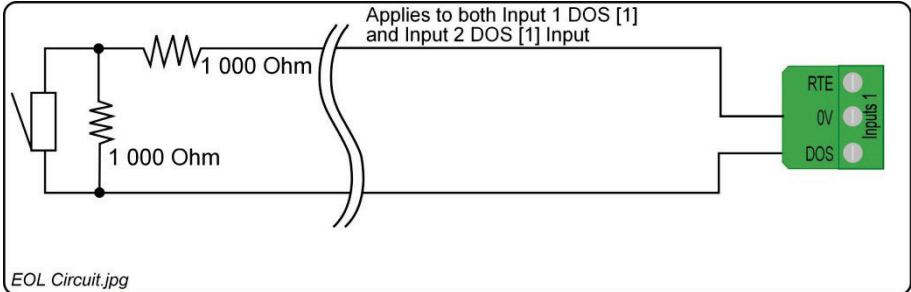

Figure 1: End-of-line (EOL) Sensing Circuit

NOTE: *End-of-line (EOL) Sensing enables the WRM to raise an alarm when somebody tampers with the circuit (cutting or shorting the wires) between either Reader 1 Inputs [1] DOS or Reader 2 Inputs [2] DOS and GROUND (GND). In other words the Module distinguishes between tampering on the circuit, and the door being in an actual 'Normally Open' state.*

By placing Resistors into the circuit between either Reader 1 Inputs DOS [1] or Reader 2 Inputs DOS [1] and GROUND (GND), the Module's Digital Input monitors a constant resistance through the circuit. When the circuit is tampered with, the Resistors are bypassed; the Module detects the resistance change and raises an alarm.

LED Status and Diagnostic Indicators

Status LED (RED)

Supply Voltage Status	Off when supply voltage is too high, or too low
Upgrade Mode	Flashing at a steady rate during upgrade
Communications Failure	Two brief flashes, repeating

Data LED (GREEN)

Digital Inputs (1-4)	Flashing Green during communication
Relays (1 and 2)	Continuous Green on detected contact closure
	Continuous Red on activation of the Relay

INSTALLATION INFORMATION

Accessories

CAUTION: DO NOT use the Metal-oxide Varistors (25 Vrms, 500 A, 77 V max clamping) with mains power applications.

Plastic Cluster Housing (HMW700)

Each Impro (WRM) Wiegand Reader Module is supplied in a Customisable Black, ABS Plastic housing, with the following features / items:

- Housing, consisting of a Base, a Cover and a selection of Cable Entry Gland Plates.
- The Housing Base has:
 - Two slots to hold the User-Selectable Cable Entry Plates
 - Six knock-out Cable Entry Points
 - Four Drill-out Cable Entry Points
- The Housing Cover and Base are held together with two Allen Head Screws (M4 x 10 mm) through the cover of the housing.
- Five Ziploc bags, containing the following:
 - Four Stand-Offs (for spacing the WRM away from the mounting surface) and two Cluster Connector Covers (for closing off the cluster connectors when not in use.)
 - Two Metal-Oxide Varistors 25 Vrms, 500 A, 77 V max clamping.
 - A 2mm Allen Key and a spare Hex Head Screw
 - Two extra gland plates
 - An extra Fixed Address Label, for installation site mapping

NOTE: *The installer needs to obtain fasteners (< 5 mm Diameter to fit through the supplied Stand-Offs) that are suitable for securing the Module to the mounting surface – these are NOT supplied in the kit.*

PCB Card for IPS Housing (HMW710)

Included in the packaging is:

- Impro Wiegand Reader PCB Card on a Base Plate.
- An extra Fixed Address Label, for installation site mapping

General

Remember the following when installing the Wiegand Reader Module:

Clustering

Clustering allows for the easy addition or replacement of Modules, it saves on wiring and requires only one DC Power Supply connection for the Cluster.

The following applies:

- The WRM may be plugged directly into its associated Cluster Controller, or into an existing Cluster consisting of a Cluster Controller and other Expansion Modules.
- No more than eight Expansion Modules can be clustered with their associated Cluster Controller.
- The WRM is powered and controlled via its Cluster Connector.
- Clustering with the Cluster Controller is recommended where **Offline Validation** is a high priority, as the WRM will have reliable access to the Tag Buffer and Memory on board the Cluster Controller.

S-Bus

S-Bus is useful when it would be convenient to install a WRM some distance from its Cluster Controller. The following applies:

- The maximum S-Bus Cable length from the Cluster Controller to the WRM is 150 m (490 ft.).
- A maximum total of 8 addresses may be connected to the S-Bus.
- The S-Bus cable should be dual core and at least 0.21 mm² (AWG24). Screened cable is recommended where interference rejection may be necessary in electrically noisy sites – and to provide SOME MEASURE* of resistance to damage from nearby lightning strikes.
- Remotely mounted WRMs will also require a suitable Isolated DC Power supply, as they are no longer plugged into the Cluster Controller.
- In the event of the S-Bus cable breaking, the WRM will stop working.

NOTE: **NOTHING can survive a direct lightning strike. Impro Technologies does NOT claim that its products are lightning proof.*

A more detailed chapter on S-Bus is included in the Impro (CCM) Cluster Controller Module Installation Manual: HCM320-0-0-GB-XX

Wiegand or Multi-Discipline Reader Distance

CAUTION: When implementing the 150 m (164 yd) cable distances with Impro Wiegand Readers use the 12 V power output option. Note, however, that the Multi-discipline Readers only connect using the 12 V power output option.

For maximum, data communications distance, install the Readers no further than 150 m (164 yd) from the Terminal. The cable individual conductor cross-sectional area should not be less than 0.2 mm^2 (0.0003 in^2).

Distance between the WRM and its Multi-mode Remote

The maximum cable distance between the Impro WRM and its Multi-mode Remote MUST NOT exceed 10 m (33 ft). Achieve this by using good quality screened, twisted pair cable.

Distance between Reader Units

To avoid mutual interference, install the Readers at least 500 mm (20 in) apart. (The same rule applies between readers on opposite sides of the same wall.)

EARTH Connection

Connect the Impro WRM ("ETH" Terminal) to a good EARTH point. Mains EARTH can be used, but electrical noise may exist.

Arc Suppression

Snubber devices are recommended for EMF Flyback and Arc Suppression when driving an inductive load with the Relay, see Figure 2.

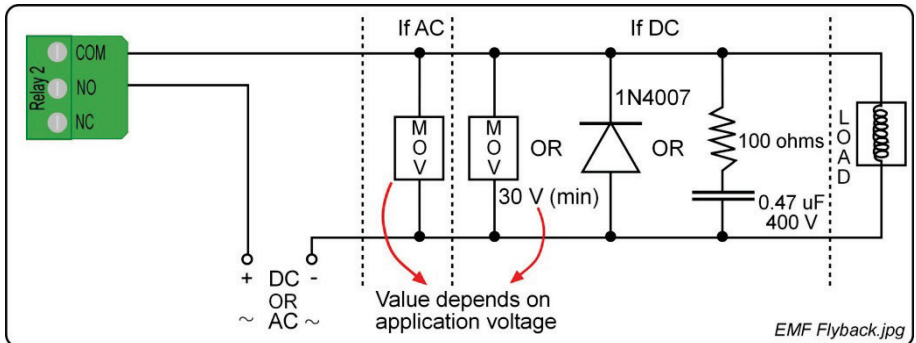

Figure 2: EMF Flyback and Arc Suppression

Mounting the Impro (WRM) Wiegand Reader Module

CAUTION: Make certain that you mount the WRM on a vibration-free surface.

NOTE: The WRM can be mounted onto virtually any surface including metal.

NOTE: Cluster Modules are Hot-Swappable – it is not necessary to power them down when adding, removing or wiring them up.

Clustering

Provided there are less than eight other Expansion Modules already clustered with the Cluster Controller, you may add the WRM to an existing Cluster:

- Remove the Housing Cover from the WRM and plug the WRM into the Cluster Socket on the right hand side of the Cluster Controller – or that of the outermost Expansion Module in the cluster.
- Holding the WRM square against its neighbouring Module, mark the mounting hole locations through the mounting holes in the back of the Housing Base.
- Remove the WRM, drill the mounting holes.
- Use the plastic Stand-Offs to provide space for cables behind the cluster, or if the other modules in the Cluster are already mounted with stand-offs.
- Mount the WRM Housing Base firmly to the mounting surface using fasteners (not included) appropriate for the mounting surface material.
- Select the gland plates that best suit the installation and/or knock out the cable entry points as needed.
- Connect the reader cables, the digital inputs and the relay terminals as necessary for the installation
- Commission the WRM (and its readers) via the menu options on the Access Control Application.
- Replace the WRM Housing Cover and fasten closed with the two Allen head screws provided.

Blank Space

Remote Mounting

When it is advantageous to mount a WRM near to the relevant door (and some distance from the Cluster Controller), the WRM may be connected to the Cluster Controller using an S-Bus cable up to a maximum of 150 m (490 ft.) long. The procedure is as follows:

- Check to see how many other Device Addresses are already connected to the S-Bus Host “D” Terminal of the Cluster Controller. No more than eight Device Addresses should be connected to an S-Bus.
- Obtain a suitable Isolated DC Power supply to power the WRM and any readers and magnetic locks, etc., that may be connected to the WRM.
- Remove the Housing Cover from the WRM and hold the module base in position, mark the mounting hole locations through the mounting holes in the back of the Housing Base.
- Remove the WRM, drill the mounting holes.
- Use the Stand-Offs to provide space for cables behind the module, if necessary – or to allow for an uneven mounting surface.
- Mount the WRM Housing Base firmly to the mounting surface, using fasteners (not included) appropriate for the mounting surface material.
- Select the gland plates that best suit the installation and/or knock out the cable entry points as needed.
- Connect the reader cables, the digital inputs and the relay terminals as necessary for the installation
- Commission the WRM (and its readers) via the menu options on the Access Control Application.
- Replace the WRM Housing Cover and fasten closed with the two Allen head screws provided.

DIP-switch Settings

NOTE: *Whenever the DIP-switch settings are modified reset the Impro WRM to acknowledge the new settings by disconnecting and reconnecting the power supply to the WRM.*

Reader 1 Select and Reader 2 Select DIP-switch Settings

Each of the Reader Ports has a 4-way DIP-switch to select the function of that Port.

NOTE: *Where you have no Advanced Wiegand Reader (Impro Multi-discipline Reader) connected, setting both Remote DIP-switches to the all off position during an Auto-ID will not return any Fixed Addresses.*

NOTE: *When Wiegand and Multi Discipline Readers are used on the same SYSTEM, all DIP Switches should take on the Wiegand settings.*













DIP-switch Position	Connections
0  DIP-switch 0 shows all the switches in the OFF position	Advanced Wiegand Reader (Impro Multi-discipline Readers). Full Tag codes and types.
1  DIP-switch 1 shows switches 2, 3 and 4 in the OFF position	No Remote attached, the Channel is used for Relay and Digital Inputs only.
2 	Impro Remote (including the Impro Multi-mode Remote).
3 	Impro RF 4-Channel Receiver or Impro (IR) Infrared Receiver.
4 	Magstripe.
5 	Barcode (code 3 of 9) with Checksum.
6 	Barcode (code 3 of 9) without Checksum.
7 	Wiegand 26-bit, 44-bit, 40-bit, 37-bit and Tag + PIN-code or Reason Code Mode. (Sagem MA100, MA200, MA300 or Sagem J-Series).
8 	Wiegand open format.
9 	LEGACY UHF Receiver Support If the UHF Receiver is connected, then Button 1 of the Quad Transmitter reports.
10 	LEGACY UHF Receiver Support If the UHF Receiver is connected, then Button 2 of the Quad Transmitter reports.
11 	LEGACY UHF Receiver Support If the UHF Receiver is connected, then Button 3 of the Quad Transmitter reports.
12 	LEGACY UHF Receiver Support If the UHF Receiver is connected, then Button 4 of the Quad Transmitter reports.

Table 1: Reader 1 Select and Reader 2 Select DIP-switch Settings

Wiegand Modes

Mode	Terminal Action
Tag Only	Treats all codes received as tag codes.
Tag + PIN	Treats the first Wiegand code received as the tag code, and the second Wiegand code received as the PIN-code.
Tag + Reason	Treats the first Wiegand code received as the tag code, and the second Wiegand code received as the Reason Code.
Tag + PIN + Reason	Treats the first Wiegand code received as the tag code. The second and third Wiegand codes received are treated as the PIN-code and Reason Code respectively.

Table 2: Wiegand Modes

Wiegand Mode Rules

- Enter PIN-codes or Reason Codes on the Reader within 10 seconds otherwise the tag code is discarded.
- The System allows 10 seconds each for the entry of the PIN-code and the Reason Code in Tag + PIN + Reason Mode.
- If the Impro WRM expects a PIN-code and receives a number greater than 65535, then the WRM assumes the number to be a tag code. The WRM discards the previously read Tag for the current one and the WRM will still expect a PIN-code.
- If the Impro WRM expects a Reason Code and receives a number greater than 65535, then the WRM assumes the number to be a tag code. The WRM discards the previously read Tag for the current one and the WRM will still expect a PIN-code or Reason Code, depending on the mode.
- If the WRM expects a Reason code and instead receives a number in the range 100 to 65535, the WRM assumes this is an error. The WRM discards the entire transaction, entering a new tag code starts the process again.
- If using PIN-codes and Reason Codes set the Impro WRM switches for Wiegand 26-bit, 37-bit, 40-bit and 44-bit, not Wiegand open format.

Blank Space

ELECTRICAL CONNECTIONS

Key Component Positions

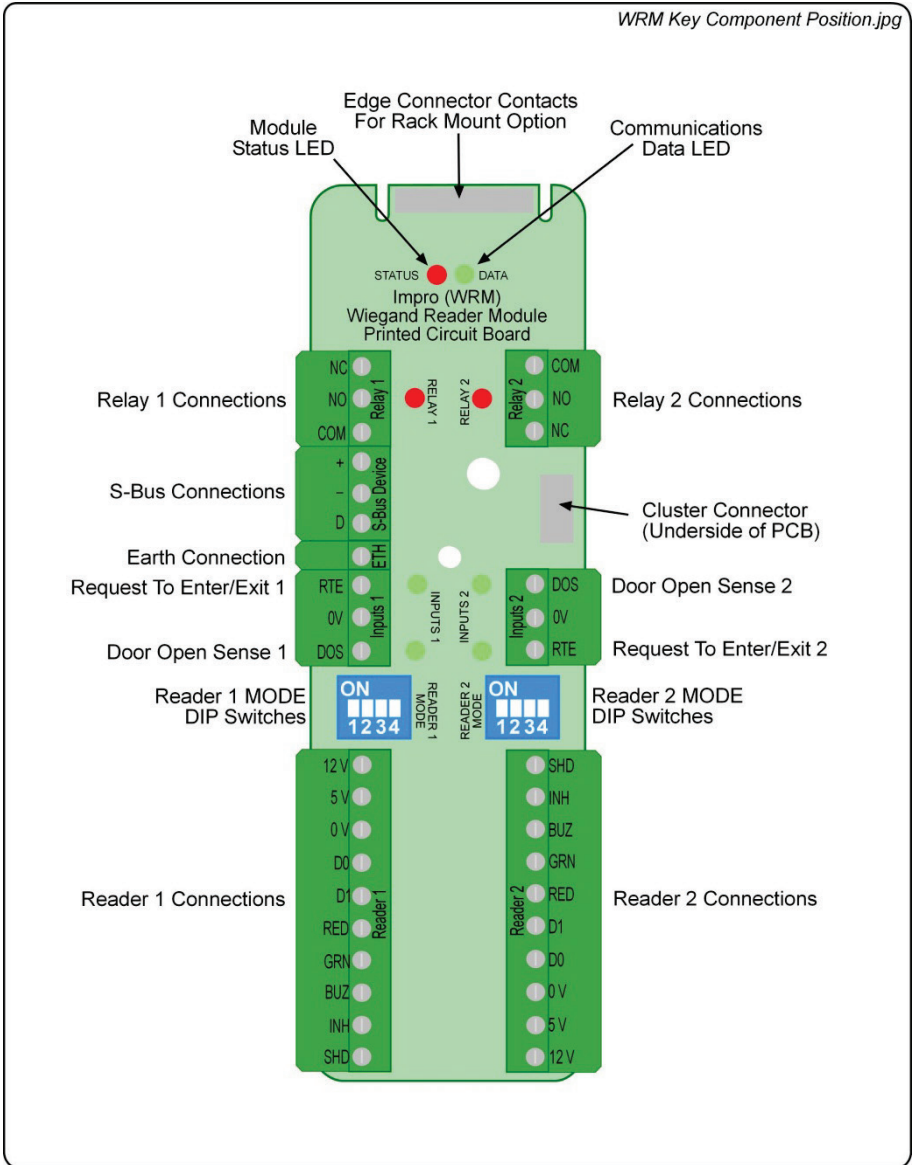

Figure 3: Impro WRM Key Component Positions

Connecting Multi Discipline Readers

Figure 4 shows a typical electrical connection diagram for the “clustered” Impro WRM.

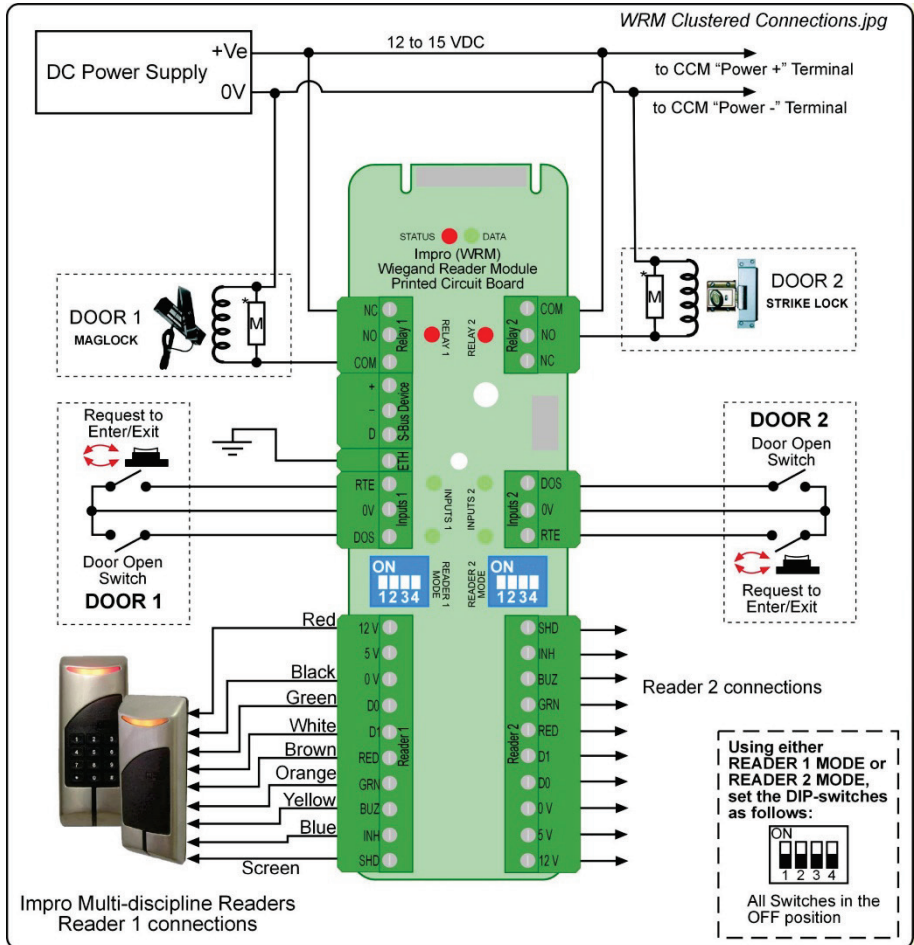

Figure 4: Typical Clustered Impro WRM Electrical Connections

NOTE: * Refer to Figure 2 for Arc Suppression details.

NOTE: The ideal cable distance between the Impro WRM and its Multi-discipline Reader **MUST NOT** exceed 150 m (164 yd).

NOTE: This diagram shows typical connections to the Impro WRM 190. Connections remain the same for all models of the Impro WRM.

NOTE: Connection details remain the same for all Multi-discipline Reader models.

Connecting to Wiegand Readers

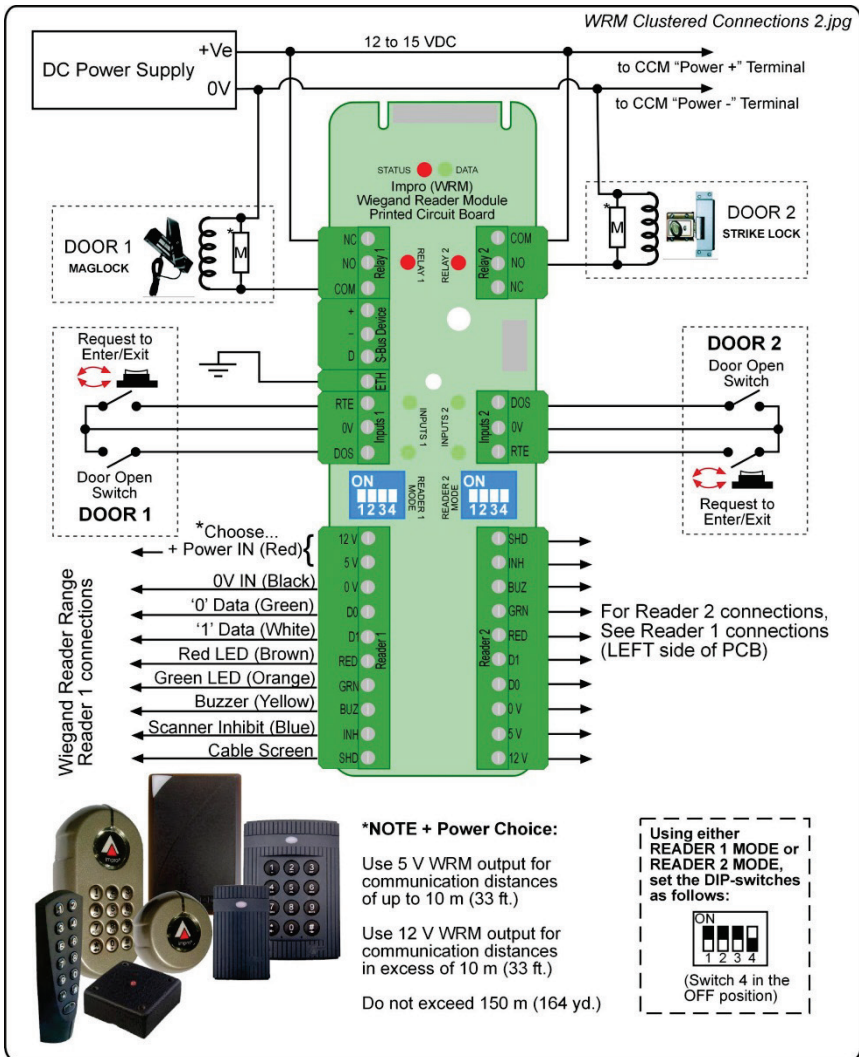

Figure 5: Connecting Impro WRM to Wiegand Reader

NOTE: When connecting the Wiegand Keypad Mullion Reader (WKM900) or the Wiegand Junction Box Reader (WJB900), use the cable colours displayed in brackets.

NOTE: Connection details remain the same for all Wiegand models.

NOTE: Use the connections shown here, when connecting a Sagem MA100, MA200, MA300 or MA500 or Magstripe Reader to the Impro WRM.

Connecting to a Multi-mode Remote

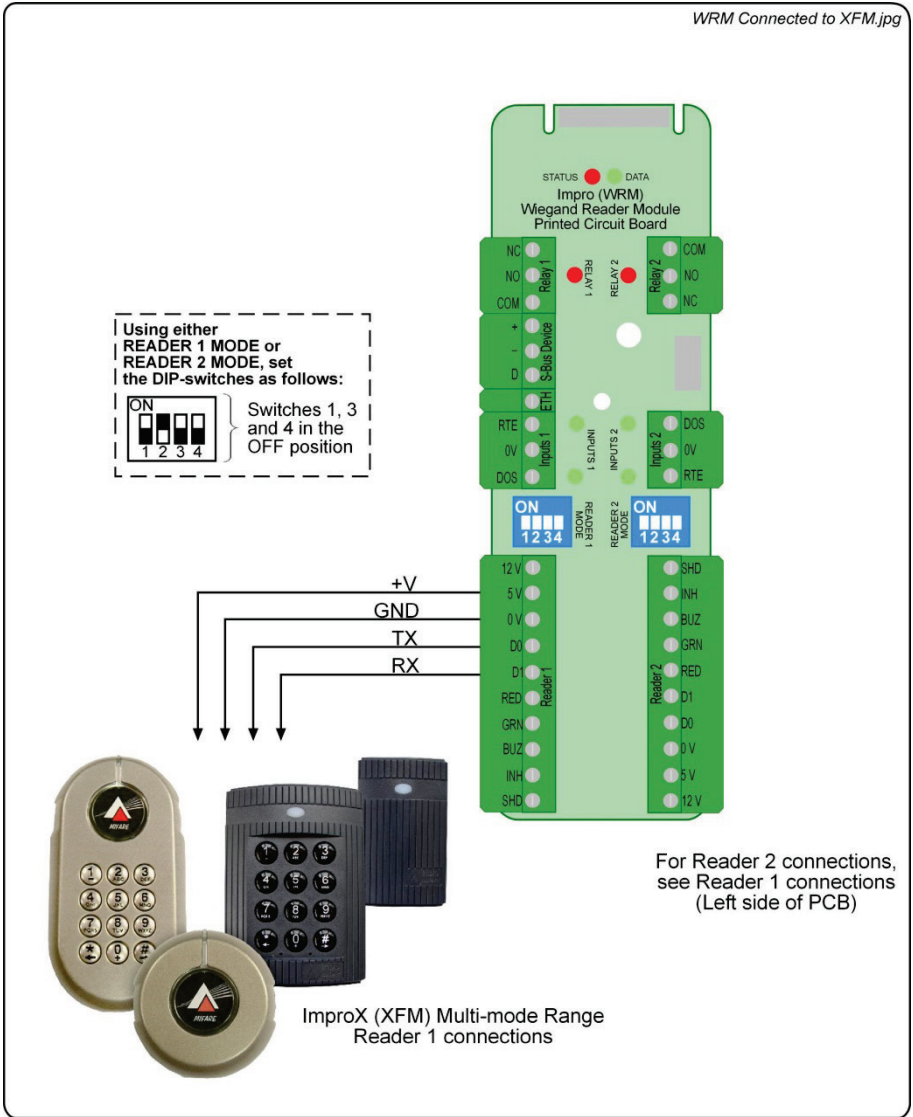

Figure 6: Impro WRM Connected to a Multi-mode Remote

NOTE: Connection details remain the same for all Multi-mode Remote models.

NOTE: The cable distance between the Impro WRM and its Multi-mode Remote MUST NOT exceed 10 m (33 ft).

Connecting other Devices

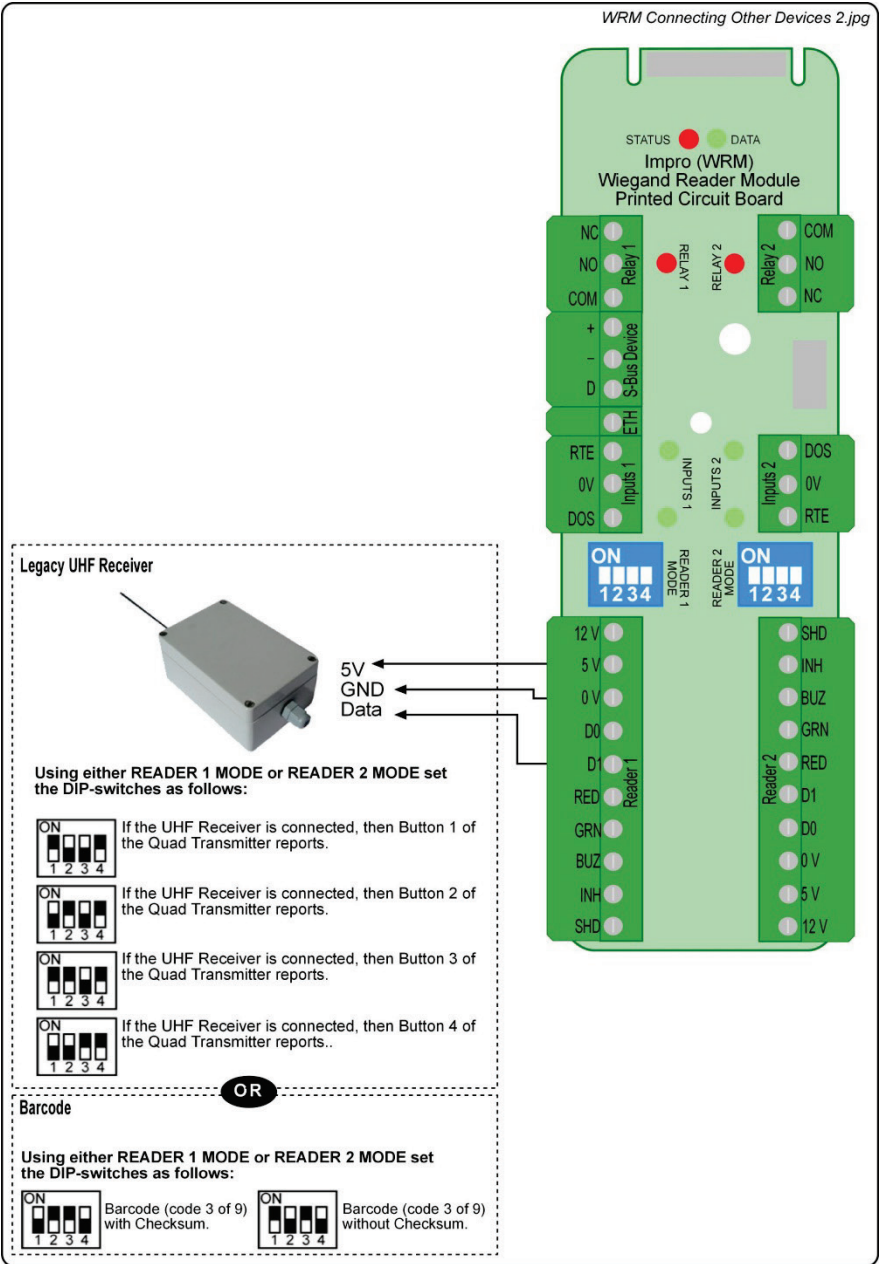

Figure 7: Connecting other Devices to the WRM

Power-on Self-test

The Power-on Self-test tests the RAM and Flash Checksums.

If any parameter in the Module Self-test fails, the connected Readers will emit a continuous beep for 2 seconds before the 2 short start-up beeps.

When the Terminal passes the Self-test, any Readers attached will emit two short beeps, each 200 ms in duration, separated by a 200 ms inter-beep pause.

WRM Address Information

Each Impro (WRM) Wiegand Reader Module is, in fact, two Reader Interfaces in one. The first Fixed Address is associated with Reader [1], and the second with Reader [2].

Each WRM is allocated two unique Fixed Addresses at the factory. These addresses are stored in the WRM's memory.

NOTE: If set to MDR mode (all dip switches off) and no MDR is connected to one channel, the fixed address for the un-used channel will be hidden. In all other instances both addresses on the WRM are always shown.

Fixed Address Label

Once the Impro WRM is installed, sketch a rough site plan. Attach the loose (additional Fixed Address Label packaged with the WRM) Fixed Address Label in the position of the Terminal on the sketched site plan. When the system installation is complete and all the units are represented on the site plan by their Fixed Address Labels, file the site plan for future reference.

GUARANTEE OR WARRANTY

CAUTION: We reserve the right to nullify the product's guarantee or warranty where you have not properly installed the Metal-oxide Varistors.

This product conforms to our Guarantee or Warranty details placed on our Web Site, to read further please go to www.impro.net.

USER NOTES

USER NOTES

USER NOTES



This manual is applicable to the Impro (WRM) Wiegand Reader Module,
HMW700-0-0-GB-01, and HMW701-0-0-GB-00

(The last two digits of the Impro stock code indicate the issue status of the product.)

HMW300-0-0-GB-00	Issue 01	October 2013	Impro\Access Portal\WRM Wiegand Reader Module\English Manuals\LATEST ISSUE\ conwrm-in-sm-en-01.docx
------------------	----------	-----------------	---