

Safety light curtain

(order no. S10667-00001)



Key to symbols



Recommendation for optimal procedure.



Risk of death in the case of non-observance.

Safety instructions



- The safety instructions in the operating manual must be observed.
- Installation and electrical connection may only be carried out by trained personnel.
- The safety light curtain complies with the requirements of Category 2 and PL=d as per EN 13849-1 and must be integrated into the operating procedure in a fault-free manner in accordance with the applicable regulations and standards in order to achieve proper protective functioning.
- In accordance with EN 12978, the safety light curtain is suitable for all door types apart from sluice and dock gates, lift doors, vehicle doors, gates used mainly in animal husbandry, textile theatre curtains, railway level-crossing barriers, barriers that are used solely for vehicle traffic, and dangerous machines that are not doors.
- During mounting, installation and commissioning, it must be ensured that the photo switch system cannot be influenced by other photo switch systems or sources of infrared light.
- The applicable standards and regulations – particularly EN 12453 (Safety in use of power operated doors) – are to be observed during mounting, installation, commissioning, maintenance and repair.
- Strictly observe the regulations of the EN12978 when connecting safety devices on power operated doors.
- The manufacturer assumes no liability for damage caused by operation and connection errors, non-observance of the operating manual or lack of maintenance or care; the manufacturer wishes to draw attention again to the possible hazardous situations that can arise in this way.
- Notwithstanding conformity with harmonised standards, it is not possible to foresee every potential risk. For this reason, persons should only be present in the hazardous area when necessary.

Purpose



The safety light curtain (LIGI) consists of a transmitter and receiver and is suitable for all automatic door types with a minimum door width of 1.6m. The LIGI complies with the following regulations: EN 12978, EN 12445 and EN 12453. The closing speed of the door is to be selected in such a way that the force limit values as per EN 12453 are adhered to. Only objects that are 5mm larger than the beam separation distance can be detected.

Mounting, installation and commissioning



Mounting, installation and commissioning of safety light curtains may only be carried out by trained personnel in accordance with the specifications of the door manufacturer. The specifications in this operating manual are also to be adhered to. Operation under conditions other than those intended and modifications to the optics and casing are not permitted and result in loss of EC conformity.

The safety light curtains are designed in such a way that sunlight and light from halogen lamps and fluorescent tubes (see IEC 61496-2) do not lead to undesired activation.

In rare cases, other photo switches or sources of infrared light can lead to undesired activation. These sources of light interference must be dealt with in such cases by switching off, blocking or removing them.



If two light curtains (in front of and behind the door) are to be used to provide protection, the separation distance between the light curtain and door should be small enough that persons cannot be present undetected between the door and the detection zones that are created. For this application, the two transmitter of the light curtains should be mounted on opposite sides of the door.

Mounting, installation and commissioning

Only one light curtain can be mounted in the door opening. In this case, the “door function” of the light curtain prevents detection by the door itself.

When the light curtain is being mounted, it is to be placed on a stable subsurface. Ensure that the ground is sufficiently level so that the sensor function can work at all points.

The first fixing clamp should be around 10cm above the ground and the last clamp should be 10cm from the end; between these points, fixing clamps should be used to fasten the profile at maximum intervals of 60cm. Optical components (transmitters, receivers, LEDs) must not be covered.

A risk assessment in accordance with the machinery directive is the basis for deciding on the selected safety method.

The alignment of the light curtain should be optimised after it has been mounted. If the test input of the light curtain is activated for longer than 15s, the light curtain switches into alignment mode. The signal reserve can be optimised in alignment mode by alternately rotating the LIGI transmitter and LIGI receiver.

If the signal reserve is less than 2, the green receiver LED flashes in this mode. The green LED remains on for signal reserves greater than 2 and the red receiver LED flashes with increasing flash frequency when the signal reserve increases. The signal reserve should be a factor of 2 or greater to ensure fault-free operation as well as to tolerate a certain amount of dirt.

As soon as the test input is deactivated for a short period, the light curtain returns to normal mode.



After installation and fine adjustment the light curtain should be switched off and back on again before the performance test. The transmitter is then self adjusting the optimum power.

Electrical connection:



The connections are made depending on the version according to the supplied circuit diagram.

Important note: The sync cable (yellow wire) is an internal connection between the transmitter and receiver which must not be connected in the controller!

Alignment mode:

This mode allows for optimum alignment of the LIGI based on a variable flash frequency of the LEDs on the receiver.

Error messages:

The LIGI has an internal error diagnosis function which indicates errors by means of an LED code depending on the type of error. In the event of an error, the LIGI switches to safe mode and the door can then only be operated in "dead man" mode.

Operating mode

Legend

- LED lit
- ★ LED flashing
- ⊗ LED off



Transmitter	
power supply = OK blinking = off	● ⊗
power supply = OK blinking = on	● ●
Test (LEDs flashing alternately)	★ ⊗ ★ ⊗ ⊗ ★ ⊗ ★

Receiver	
Free detection zone	● ⊗
Interrupted detection zone	⊗ ●
Test (LEDs flashing alternately)	★ ⊗ ★ ⊗ ⊗ ★ ⊗ ★

Alignment mode

Legend

- LED lit
- ★ LED flashing
- ⊗ LED off



Transmitter	
Alignment mode (LEDs flashing alternately)	● ⊗ ● ⊗ ★ ⊗ ★ ⊗

Receiver	
Excess gain less than 2	● ⊗ ● ⊗ ⊗ ⊗ ⊗ ⊗ Green LED flashing
Excess gain greater than 2	● ● ● ● ⊗ ★ ⊗ ★ Flash frequency of red LED increases with signal reserve

Alignment mode is accessed by activating test or alignment mode for at least 15s and for the duration of alignment.

Rotating the transmitter and receiver increases or reduces the reception level. The more the level increases, the faster the flash frequency of the red LED will be.

When the maximum flash frequency is reached, the light curtain is optimally aligned and can be fastened in place.

The test input (T00 version) is only required for alignment when using the OSE output versions. Connect to 0V/GND in normal operation.

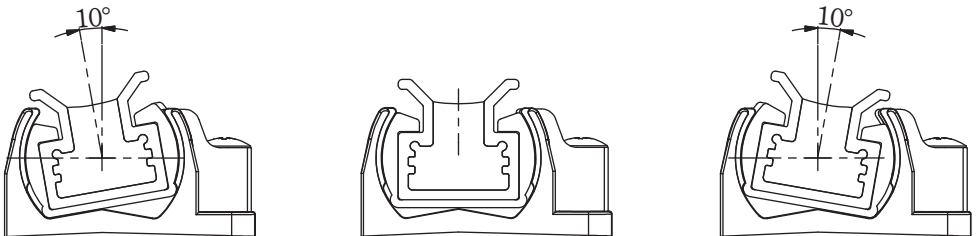

Error mode

Legend

- LED lit
- ★ LED flashing
- ⊗ LED off



	Transmitter	Error mode	Receiver	
No supply voltage	⊗ ⊗		⊗ ⊗	Check supply voltage
Receiver polarity reversed	● ● ● ● ★ ★ ★ ⊗	Yellow LED flashes 3x, long pause	⊗ ⊗	Check receiver operating voltage
Short at output		Red LED flashes 2x, long pause	⊗ ⊗ ⊗ ⊗ ★ ★ ⊗ ⊗	Check output cable, overload, wrongly connected, cable defective, output on light curtain defective
Error in sync cable	⊗ ⊗ ⊗ ⊗ ★ ★ ★ ⊗	Yellow LED flashes 3x, long pause		Check sync cable (yellow), may only be connected between transmitter and receiver
Internal device error	★ ⊗ ★ ⊗ ★ ⊗ ★ ⊗	All LEDs flashing	★ ⊗ ★ ⊗ ★ ⊗ ★ ⊗	Light curtain must be replaced

Light control

Installation options	Notes	Transmitter connection
Installation at door level (with door function)	Interruptions to the light beam in the door do not lead to detection.	OSE-LIGI: brown - 10-30 V DC white - 0 V/GND
Installation in front of door noncritical standard doors (without door function)	Door and floor have matt surfaces.	OSE-LIGI: brown - 0 V/GND white - 10-30 V DC
Installation in front of door critical doors; critical floors (without door function)	<p>Critical points: Part or all of the door has a highly reflective surface.</p> <p>Increased functional safety can be achieved by programming the signals when the door is open (see descriptions below).</p>	OSE-LIGI: brown - 0 V/GND white - 10-30 V DC

Installation steps (critical doors and floors / without door function):

For increased functional security when installing in front of the door, the reception signals (reference values) must be programmed into the light curtain when the door is open and the area to be protected is clear.

- The LIGI is installed as explained in the operating instructions, i.e. the transmitter is connected as indicated in the table above (bottom row).
- **When the door is open and the area to be protected is clear, the sync connection between the transmitter and receiver is connected/hot-wired with 10-30 V DC using a short filament for a very short period of time (less than 1s). Everything else will now happen automatically.**
- If the previous step has been carried out correctly, the green LED on the receiver will be continuously on and the red LED will flash. The reference values will then be programmed. It is essential to keep the area to be protected clear during this time. This programming process will take 10s and the red LED will then go out.

Installation and starting up with light control

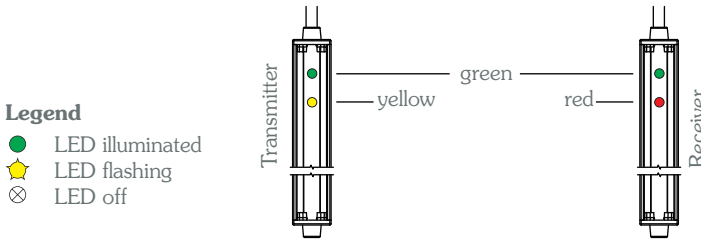

Legend

- LED illuminated
- ★ LED flashing
- ⊗ LED off

Receiver	
Area to be protected clear	● ⊗
Programming phase after connection for 1s	● ● ● ● ● ● ● for 10s ★ ⊗ ★ ⊗ ★ ⊗ ★
Programming phase complete	● ⊗

Additional information:

- If something went wrong during the programming process explained above (e.g. accidental interruption of light beam or if the adjustment was subsequently changed), the programming process can be repeated as often as required.
- If the sync connection between the transmitter and receiver is connected with 10-30 V DC for longer than 15s and less than 25s, all the saved reference values from the programming process will be actively deleted, i.e. the factory settings are restored. Once the above connection has been disconnected, the green and red LEDs on the receiver will illuminate for 2s; this confirms that the reference values have been deleted. At this setting the light curtain is typically used for uncritical ambient conditions.

Receiver	
Connect sync 15s to 25s with 10-30 V DC.	⊗ ⊗ ⊗ ⊗ ⊗ ⊗ ⊗ ⊗ ⊗ ★ ★ ★ ★ ★ ★ ★ ⊗
Connection to sync disconnected again.	● for 2s ●

Testing

The operation of the light curtain is to be tested as follows once it has been mounted.

1. A test rod with a diameter of 50mm must be continuously detected over a range of 0mm to 500mm above the ground.
2. A test object with an edge length of 200mm must be continuously detected over a range of 0mm to 2500mm above the ground. The test bodies should be moved from bottom to top during these tests.

Top view:

Door and recommended light curtain layout of T=transmitter and R=receiver

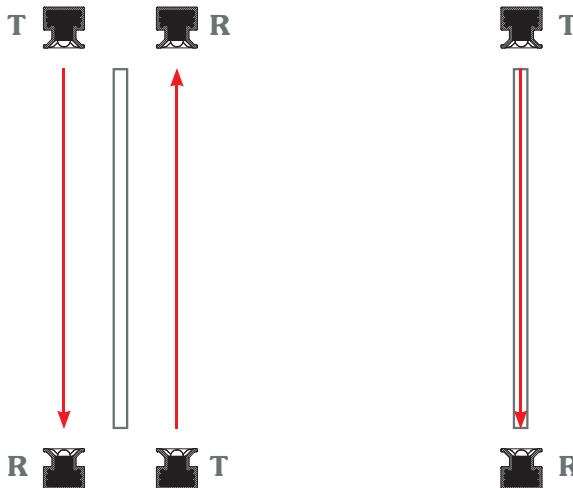

Figure 1
Without door function
(Blanking function)

Figure 2
With door function
(Blanking function)

Maintenance and repair



The safety light curtain does not have any wearing parts that need to be maintained.

The light entry and exit openings are to be cleaned regularly, depending on the dirt that occurs. Use a cloth with soapy water or a water jet for this purpose. High-pressure cleaners, abrasives and organic solvents must not be used.

Check regularly whether the light curtains are correctly aligned. Adjust the alignment if necessary. The light curtain casing, the optics areas, the plug and the connection cable are to be checked regularly for damage. Parts with significant damage must be replaced.

Furthermore please check detection ability on a regular basis as per manual page 9.



If light curtains are replaced, they must only be replaced by identical light curtains or by other safety light curtains that are intended for the relevant door by the door manufacturer.

Transmitter and receiver light curtains must only be replaced in pairs so as to ensure that the same software and hardware status is present.

Repairs must only be carried out by trained personnel.

Versions

Number of channels: 23 channels

Connection:

Connection cables 5m and 15m, the total length must not exceed 25m

Connection plug Pig-tail connector with M8 plug, 4-pin, L=130mm

Door function:

Continuous interruption starting at the top light beam and going towards lower light beams does not lead to detection as this is interpreted as lowering of the door.

After stopping for more than 1.5s interruption will be shown.

Only after complete opening of the door an uninterrupted detection zone will be signalled at the output.

After that automatic closing is possible.

Technical data

Safety parameters	ESPE type 2 as per IEC 61496-2 MTTF _D > 100 years; DC _{AVG} > 99% Category 2; PL d (PFH=7.33·10 ⁻⁹ 1/h) as per EN 61508-2; Category 2 for LIGI-xx-Nxx and LIGI-xx-Pxx with only one suitable external control system for testing
Door widths	1.6 to 10m
Rated voltage	24V DC -58% +25% (10 to 30V DC)
Current consumption	Transmitter: Approx. 30mA (24V DC) Receiver: Approx. 20mA (24V DC)
Power consumption	Approx. 1.2W
Detection zone height	2520mm
Channel count	Max. 23
Type of light	Modulated infrared
Type of switching:	Light switching, i.e. the following applies for free detection zones: OSE output = Alternating signal (approx. 950Hz)
Aperture angle	Approx. ±5°
Detection capability	0 to 500mm, detection object ≥ 50mm 500 to 2520mm, detection object ≥ beam separation distance + 5mm
Door function	max. door speed: (version A; bottom part > 100mm) → 1,1m/s (version A; bottom part > 125mm) → 1,3m/s (version C; bottom part > 370mm) → 1,3m/s
OSE output	Approx. 950Hz, alternating signal, 4V 20mA, short proof, reverse polarity protection, max. 100nF, max. 30μA leakage current, integrated pull-down 220Ω

Technical data

Ambient light safety	≥100klux
Housing material	Aluminium profile, fully filled, with 2K epoxy resin
Connection	Pig-tail M8 plug 4-pin, L=130mm
Degree of protection	IP67 as per EN 60529
Operating temperature	-20 to +60°C
Storage temperature	-30 to +70°C
Air humidity	Max. 95%
Weight	Approx. 1860g
Dimensions	2640x16x16mm (LxWxH)

switching time	Definition
t (turn on delay) ≤ 100ms	light beam interruption
t (turn off delay) ≤ 800ms	uninterrupted detection zone

Connection scheme, OSE output

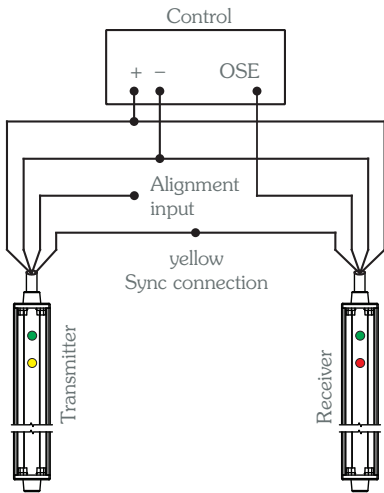

Transmitter

1 brown - 10...30VDC
3 white - 0V/GND
1 brown - 0V/GND
3 white - 10...30VDC

Function Setting

with blanking
without blanking

- 2 yellow - Sync connection → Receiver
- 4 green - Alignment input

Receiver

- 1 brown - 10...30VDC
- 3 white - 0V/GND
- 2 yellow - Sync connection → Transmitter
- 4 green - OSE output 950Hz

*GIGAcontrol A
(Menu items 1200 / 1220)

Terminal	(OSE1)	(OSE2)
+	23	26
-	21	24
OSE	22	25

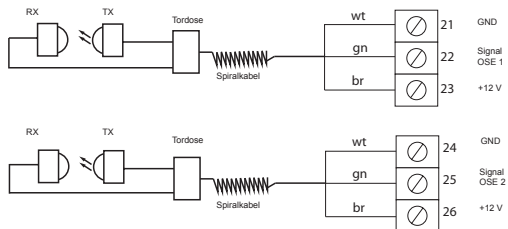

Mounting materials

Direct mounting

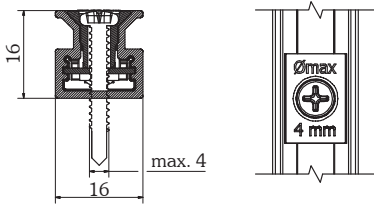

LIGI-JK 10 alignment clamp

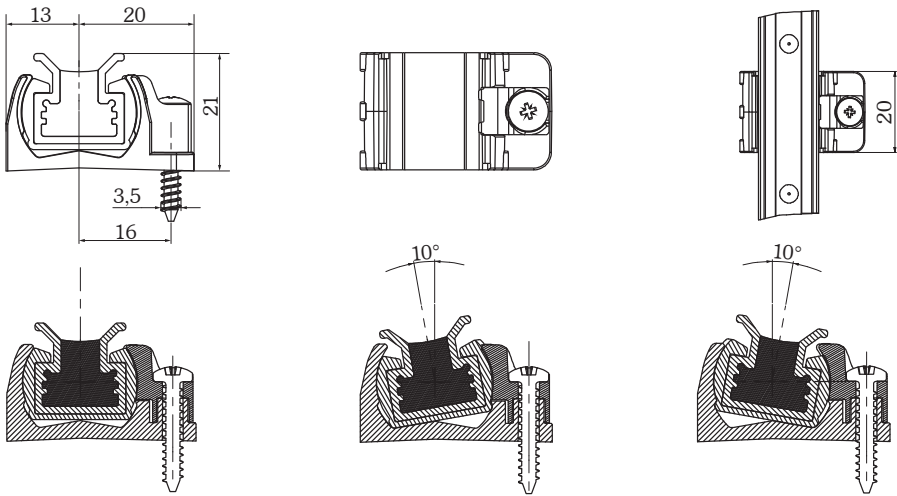

LIGI-HK 10 fixing clamp

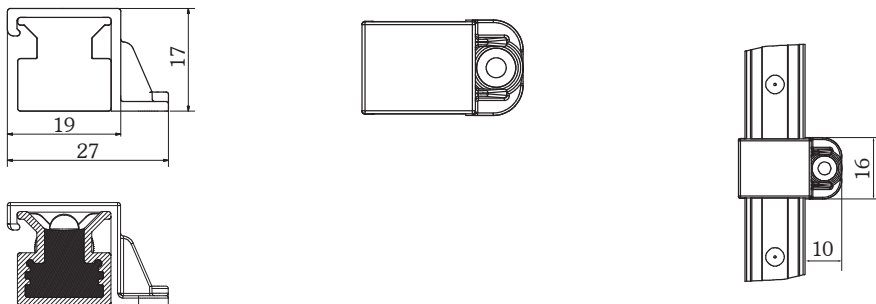

Channel selection

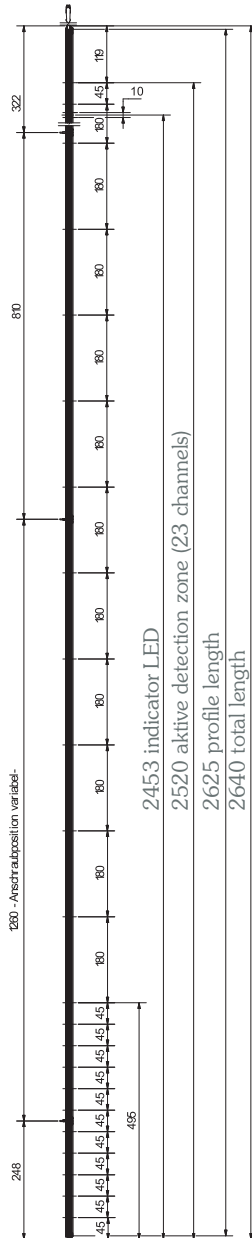

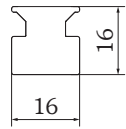
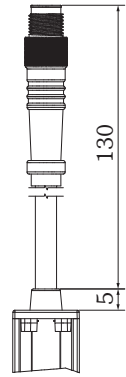
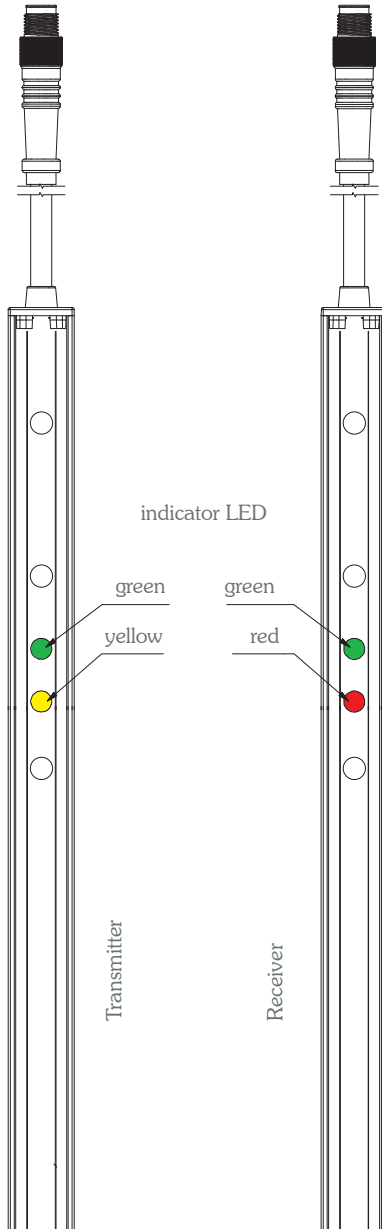
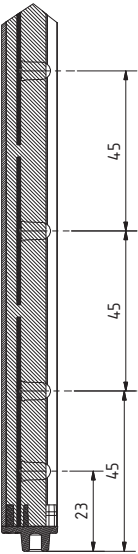
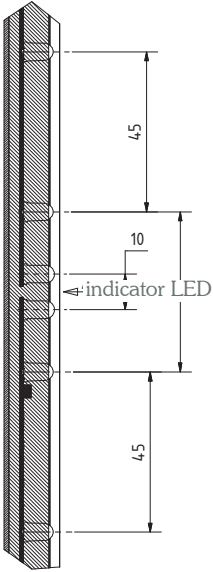

EG-Baumusterprüfbescheinigung EC type-examination certificate

Hiermit wird bescheinigt, dass das unten beschriebene Produkt der Firma
This certifies that the product described below from company

WITT Sensoric GmbH
Gradestraße 48-50
12347 Berlin
Deutschland

die Anforderungen des Anhangs I der Maschinenrichtlinie 2006/42/EG als eine Grundlage für die EG-Konformitätserklärung erfüllt.
meets the requirements of Annex I of the Directive 2006/42/EC as a basis for the EC declaration of conformity.

Geprüft nach **EN 12978:2003+A1:2009**
Tested in accordance with **EN ISO 13849-1:2008**
IEC 61496-2:1997
EN 12445:2000 Chap.7
EN 12453:2000 Chap.5.5.1

Beschreibung des Produktes **Lichtgitter für Toranwendungen**
(Details siehe Anlage 1) **Light curtain for door applications**
Description of product
(Details see Annex 1)

Typenbezeichnung **LIGI**
Type Designation

Registrier-Nr. / *Registered No.* 44 205 13169201
Prüfbericht Nr. / *Test Report No.* 3512 5434
Aktenzeichen / *File reference* 8000423309

Gültigkeit / *Validity*
von / *from* 2014-03-20
bis / *until* 2019-03-19



TÜV NORD CERT GmbH
Zertifizierungsstelle Maschinen
Certification Body Machinery
Benannte Stelle 0044 / *Notified Body 0044*

Essen, 2014-03-20

TÜV NORD CERT GmbH Langemarckstraße 20 45141 Essen www.tuev-nord-cert.de machinery@tuev-nord.de

Bitte beachten Sie auch die umseitigen Hinweise
Please also pay attention to the information stated overleaf

EG-Konformitätserklärung

**nach EMV-Richtlinie 2014/30/EU
und Maschinenrichtlinie 2006/42/EG**

Für die folgend bezeichneten Geräte
Sicherheitslichtgitter LIGI zur Absicherung von Türen und Toren
hergestellt nach den Fertigungsvorschriften 2.10376-399
mit folgenden Typ-Bezeichnungen:

Name	Geh.	Ausg.	Test	Strahl- typ	Kanal- anzahl	Schutzfeld- höhe	Torfunktion mit / ohne	Kabel	Sonder- ausf.
LIGI	01 02 11	OSE	T00	A B C	12..57	495..2520mm	F00 F01 F05	C00	S000
		P01	T01						
		P02	T02						
		N01	T03						
		N02	T04						
		R01	T05						
		R02 R03							

wird hiermit bestätigt, dass sie den einschlägigen Bestimmungen der oben genannten EG-Richtlinien entsprechen. Zur Beurteilung der Geräte wurden folgende Normen herangezogen:

- EN 61326-3-2 Elektrische Mess-, Steuer-, Regel- und Laborgeräte - EMV-Anforderungen - Teil 3-2: Störfestigkeitsanforderungen für sicherheitsbezogene Systeme und für Geräte, die für sicherheitsbezogene Funktionen vorgesehen sind (Funktionale Sicherheit) - Industrielle Anwendungen in spezifizierter elektromagnetischer Umgebung
- EN 61000-6-3 Elektromagnetische Verträglichkeit (EMV) - Teil 6-3: Fachgrundnormen - Störaussendung für Wohnbereich, Geschäfts- und Gewerbebereiche sowie Kleinbetriebe
- EN 12978 Schutzeinrichtungen für kraftbetätigte Türen und Tore – Anforderungen und Prüfverfahren
- EN ISO 13849-1:2008
Kat. 2 und PL-d Sicherheit von Maschinen – Sicherheitsbezogene Teile von Steuerungen Teil 1: Allgemeine Gestaltungsleitsätze
- IEC 61496-2
Typ 2 Sicherheit von Maschinen – Berührungslos wirkende Schutzeinrichtungen Teil 2: Besondere Anforderungen an Einrichtungen, welche nach dem aktiven opto-elektronischen Prinzip arbeiten

Bevollmächtigt für die Zusammenstellung der technischen Unterlagen ist
Witt Sensoric GmbH, 12489 Berlin, Ernst-Lau-Straße 12

Diese Erklärung wird verantwortlich für den Hersteller
Witt Sensoric GmbH, 12489 Berlin, Ernst-Lau-Straße 12

abgegeben durch Herrn Jörg Brech (Geschäftsführer).

Berlin, 12.02.2016



Witt Sensoric GmbH
Ernst-Lau-Straße 12
D - 12489 Berlin
Tel.: 030 - 75 44 94 - 0
Fax: 030 - 75 44 94 - 11



SOMMER
Antriebs- und Funktechnik GmbH
Hans-Böckler-Str. 21-27
D-73230 Kirchheim/Teck
Telefon 07021/8001-0
Telefax 07021/8001-100
info@sommer.eu www.sommer.eu

05/2016